

## The Determination of the Handedness of Cholesteric Superhelices Formed by DNA Fragments

Gian Piero Spada,<sup>a</sup> Patrizia Brigidi,<sup>b</sup> and Giovanni Gottarelli<sup>\*a</sup>

<sup>a</sup> *Dipartimento di Chimica Organica, Università di Bologna, via S. Donato 15, I-40127 Bologna, Italy*

<sup>b</sup> *Cattedra di Chimica delle Fermentazioni e Microbiologia Industriale, Facoltà di Farmacia, Università di Bologna, Italy*

Circular dichroism shows that small segments of right-handed B-DNA in solution interact together to give a left-handed cholesteric superhelix.

Many important biological macromolecules have helical structures. In several organs these helices are organized in superhelical structures. For example, Dinoflagellate chromosomes and the organic matrix of the cuticle of certain crabs (mainly chitin) show structures analogous to cholesteric liquid crystals (CLC).<sup>1</sup> Also protein  $\alpha$ -helices pack together at an angle rather than parallel.<sup>2</sup> We therefore think that the determination of the handedness of these and analogous cholesteric systems is of interest.

Recently Brandes and Kearns<sup>3</sup> reported that small fragments of DNA form CLC which can be oriented with magnetic fields. The individual DNA helices which are the building structures of these phases have negative diamagnetic anisotropy, *i.e.*, they orientate with their long molecular direction perpendicular to an external magnetic field; therefore, the cholesteric superhelices can be oriented with their axes either parallel to the cell surface to give fingerprint textures, or perpendicularly to them to give planar textures. From the fingerprint textures, it is possible to obtain the pitch of the superhelices, while planar texture are ideal for optical spectroscopic studies (see Figures).

We have prepared CLC starting from highly polymerized calf thymus DNA (Sigma) which was sonicated with a Artek Ultrasonic 2000 (300 W) in short cycles for a total time of 60 minutes at a temperature between 0 and 5°C. The molecular

weight distribution was found to be around a maximum of 120 bp by agarose gel electrophoresis (the molecular weight marker was pBR322·Hae III with fragment length ranging from 587 to 8 bp). Deproteination was carried out with standard procedures. The final concentration was 250 mg DNA/ml buffer solution (10 mM Tris, 1 mM ethylenediaminetetra-acetic acid (EDTA), pH 8). Planar textures

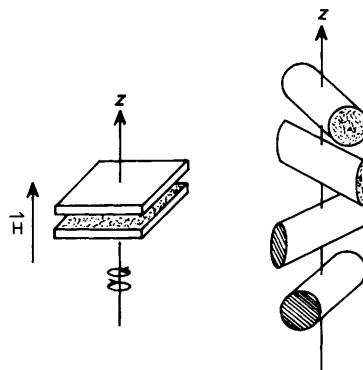
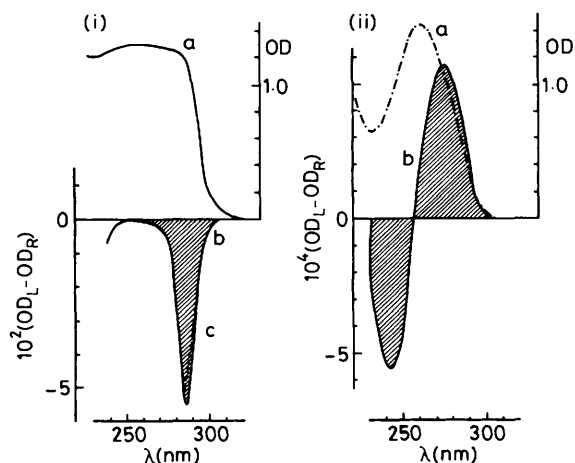

Figure 1. Sketch of the planar alignment with the superhelix axis parallel to the applied magnetic field (direction of propagation of light).



**Figure 2.** (i): a, The absorption; b, circular dichroism spectra of a CLC formed by DNA fragments in a 10 μm cell (planar texture, see Figure 1); c, the CD spectrum is nearly unaffected by rotation of the cell by 90° about the optical axis of the light beam; this ensures that artefacts due to linear dichroism contributions are minimal. (ii): a, The absorption and b, circular dichroism spectra of an isotropic diluted solution of DNA fragments in a 1 cm cell.

were obtained in a 10 μm cell which was left overnight in a 8 kG magnet with the magnetic field perpendicular to the cell walls. The Circular Dichroism (CD) (see Figures) shows an intense negative maximum in correspondence to the absorption of the bases and has all the characteristics of the CD of a CLC in an absorption region.<sup>4,5</sup> The handedness of the cholesteric superhelices can be correlated to their CD spectra by equation (1), which was developed from a model composed

$$(\text{OD}_L - \text{OD}_R)_i = P \cdot \nu_i^3 \cdot \Delta n \cdot (\text{OD}_{\parallel} - \text{OD}_{\perp})_i / 2(\nu_i^2 - \nu_0^2) \quad (1)$$

of a helical array of stacked chromophores.<sup>4,6</sup> Here  $(\text{OD}_L - \text{OD}_R)_i$  is the CD at frequency  $\nu_i$ ,  $\nu_0$  is the frequency of the selective reflection (in our case, from the fingerprints textures, the pitch is ca. 2–2.5 μm and  $\nu_0$  is in the i.r.),  $\Delta n$  is the optical anisotropy (negative in our case),<sup>7</sup>  $P$  is positive for a right-handed helix and  $(\text{OD}_{\parallel} - \text{OD}_{\perp})_i$  is the linear dichroism of the helix building layers (negative for DNA).<sup>8</sup> Therefore the negative CD indicates a left-handed superhelix. We are confident in this assignment as we have already studied by CD spectroscopy the handedness of thermotropic<sup>9</sup> and micellar<sup>10</sup>

CLC and ion both cases the assignments were confirmed by independent techniques. Our result is further supported by the experiments recently described by Maestre and Reich:<sup>11</sup> a thin film of DNA is sandwiched between two quartz plates; when the plates are twisted to generate a right-handed superhelix a positive CD at ca. 290 nm is obtained, whereas negative CD instead is correlated to opposite twisting of the plates.

The left-handed twist of DNA CLC is likely to occur also in more complex structures formed by non-degraded DNA; a recent elegant electron microscopic study reports a left-handed sense of twist for Dinoflagellate chromosomes.<sup>1</sup>

The fact that right-handed helices of B-DNA interact to give a left-handed superhelix is somehow surprising as, following a pure steric model (a classical model of cholesteric LC, formed by piling up several rigid right-handed screws, gives a right-handed superhelix) one would have expected a right-handed superhelix; however, the DNA helix is rather 'steep' (the pitch/diameter ratio is ca. 1.54 for B-DNA) and in general a purely steric interaction is probably an inadequate model.<sup>12</sup>

We thank MPI and CNR (Rome) for financial support and Drs. F. Livolant and M. Maestre for discussion.

Received, 4th January 1988; Com. 8/00022K

## References

- 1 F. Livolant, M. M. Giraud, and Y. Bouligand, *Biol. Cellulaire*, 1978, **31**, 159.
- 2 F. H. C. Crick, *Acta Crystallogr.*, 1953, **6**, 689.
- 3 R. Brandes and D. R. Kearns, *Biochemistry*, 1986, **25**, 5890.
- 4 R. J. Dudley, S. F. Mason, and R. D. Peacock, *J. Chem. Soc., Faraday Trans. 2*, 1975, 997.
- 5 F. D. Saeva, 'Liquid Crystals,' M. Dekker, New York, 1979, ch. 6.
- 6 E. Sakmann and J. Voss, *Chem. Phys. Lett.*, 1972, **14**, 528.
- 7 F. Livolant, *J. Physique*, 1987, **48**, 1051.
- 8 M. Eriksson, B. Nordén, P. O. Lycksell, A. Graslund, and B. Jernstrom, *J. Chem. Soc., Chem. Commun.*, 1985, 1300; and references therein.
- 9 G. Gottarelli, B. Samorì, C. Stremmenos, and G. Torre, *Tetrahedron*, 1981, **37**, 395.
- 10 G. P. Spada, G. Gottarelli, B. Samorì, C. Bustamante, and K. S. Wells, *Liquid Crystals*, 1988, **3**, 101.
- 11 M. F. Maestre and C. Reich, *Biochemistry*, 1980, **19**, 5214.
- 12 M. A. Osipov, *Chem. Phys.*, 1985, **96**, 2509; S. G. Skuridin, H. Damaschun, G. Damaschun, Y. M. Yevdokimov, and R. Misselwitz, *Stud. Biophys.*, 1986, **112**, 139.